



Technical Specification		
Broadband Horn Antenna		
Item	Specification	Unit
Model	ZK-KDLB0220	
Frequency Range	0.2-2	GHz
Gain	10 Typ.	dB
VSWR	2 Typ.	
Polarization	Linear	
Connector	N-50K	
Power Handing(W)	300 Max	
Material	Al	
Color	Grey	
Size	705*860*904	mm



Chengdu Zontek Technology Co.,Ltd.

Outline Drawing:

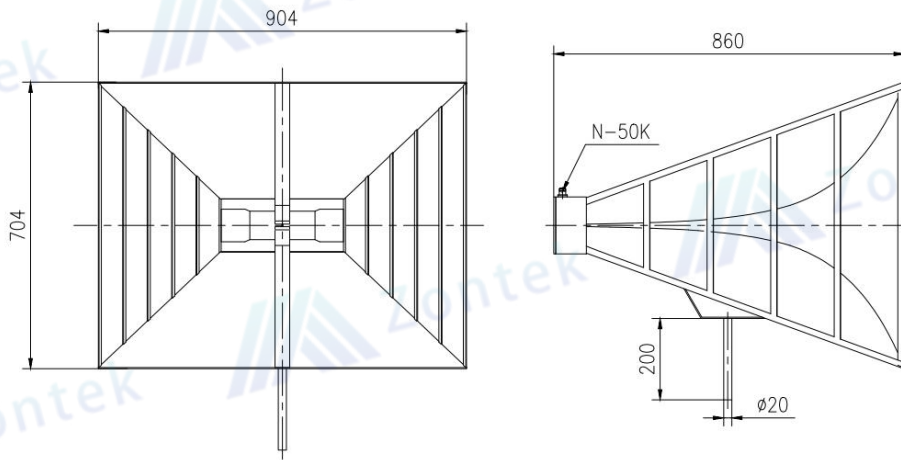

VSWR:

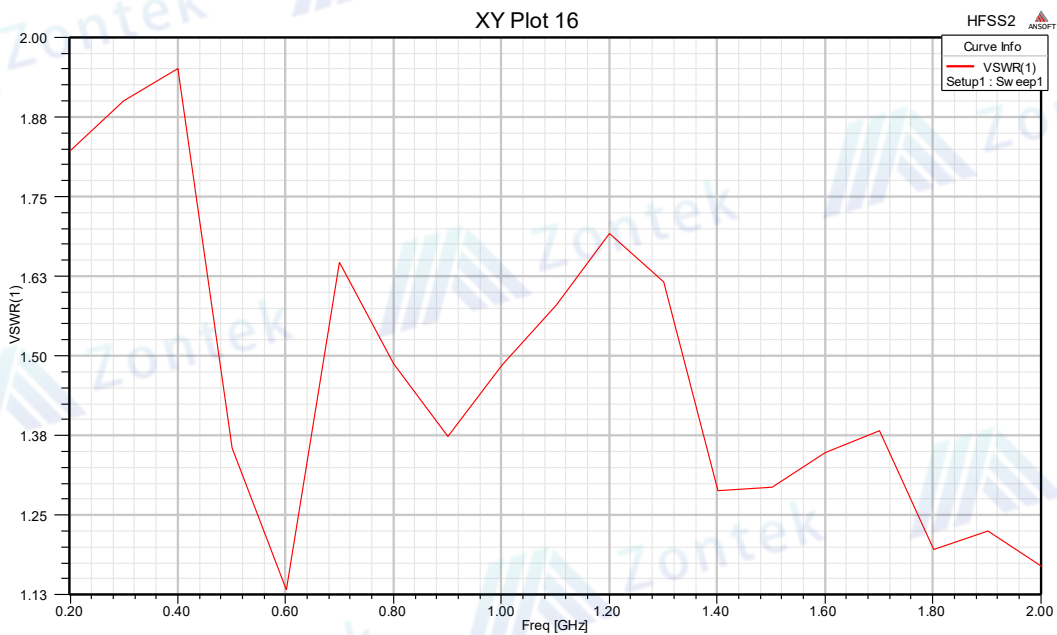



Chengdu Zontek Technology Co.,Ltd.

Gain:

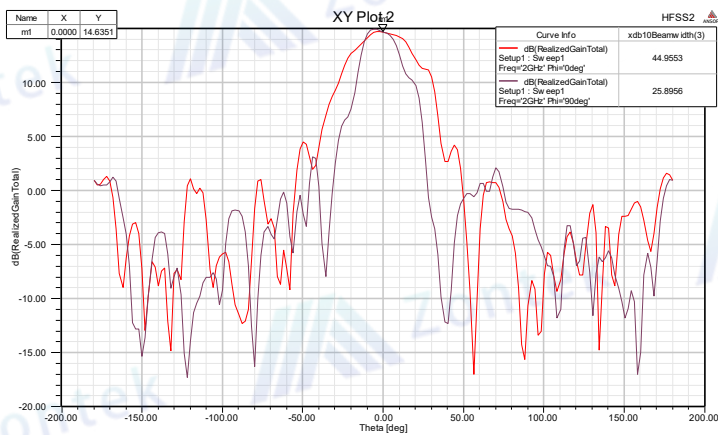
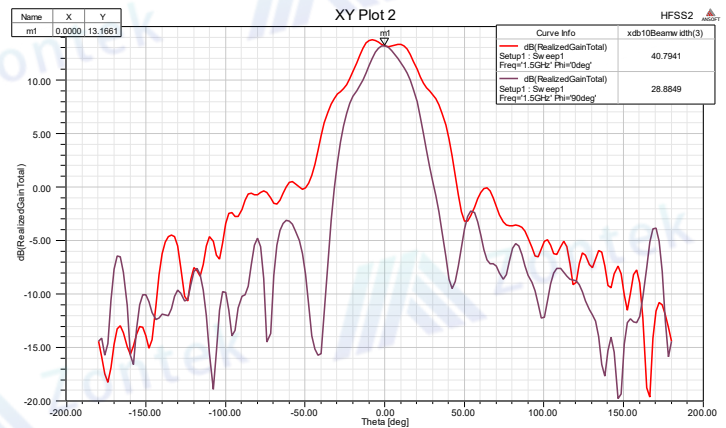
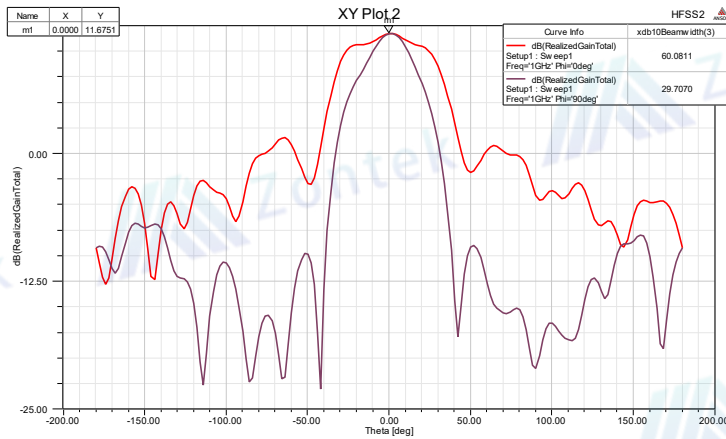
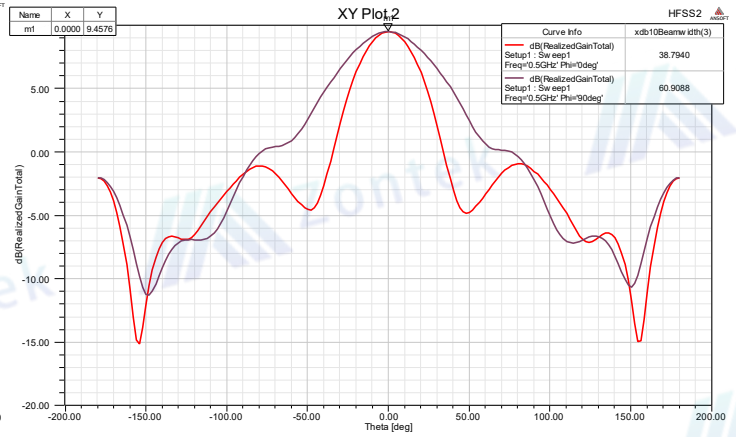
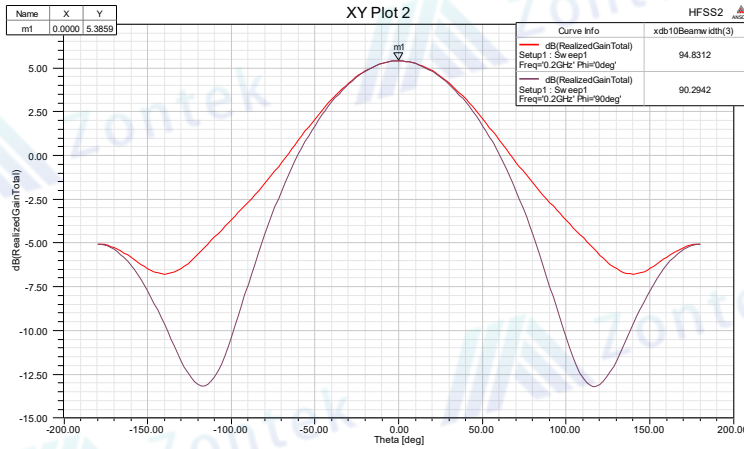

Website: www.a-microem.com Email: salesdirector@a-microem.com Tel: (+86) 028-89541190
Data for reference only, for more information, please contact: salesdirector@a-microem.com