

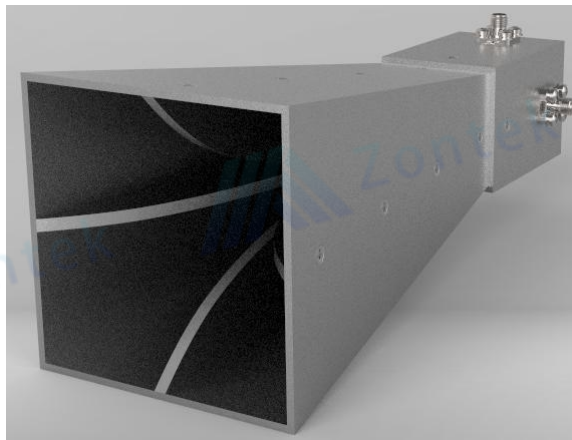

Technical Specification		
Dual Polarization Horn Antenna		
Item	Specification	Unit
Model	ZK-SJLB10180	
Frequency Range	1-18	GHz
Gain	≥ 12	dB
VSWR	2 Typ.	
Polarization	Dual Linear	
Connector	SMA-50K	
Power Handing(W)	50 Max	
Material	Al	
Color	Grey	
Size	316*177*177	mm





Chengdu Zontek Technology Co.,Ltd.

Outline Drawing:

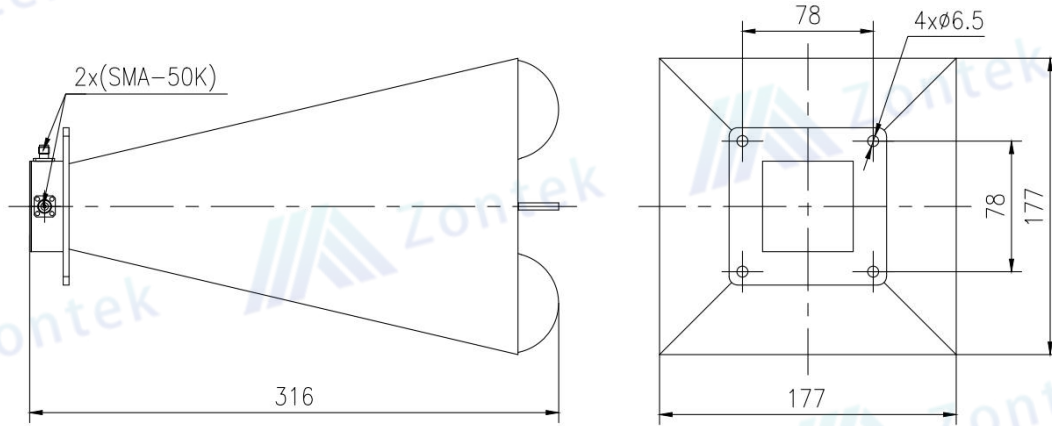

VSWR:

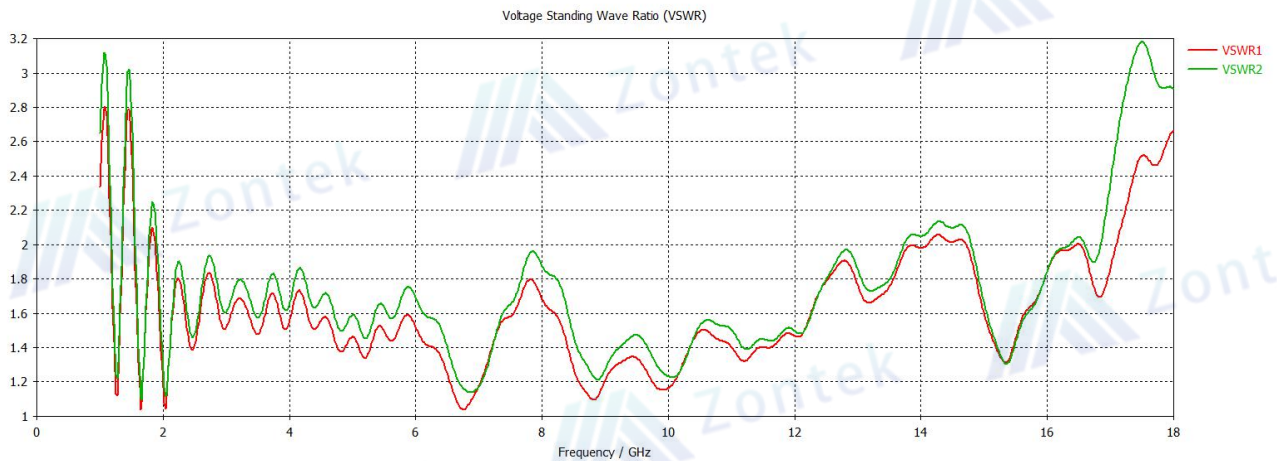



Chengdu Zontek Technology Co.,Ltd.

Gain:

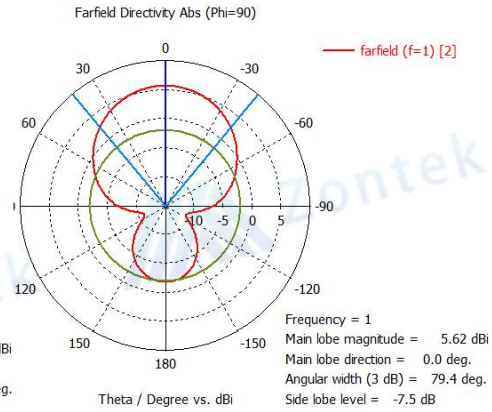
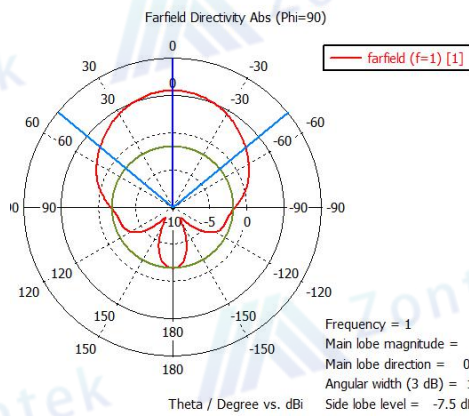

@1GHz

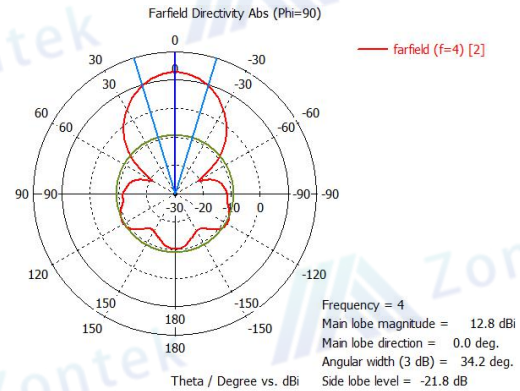
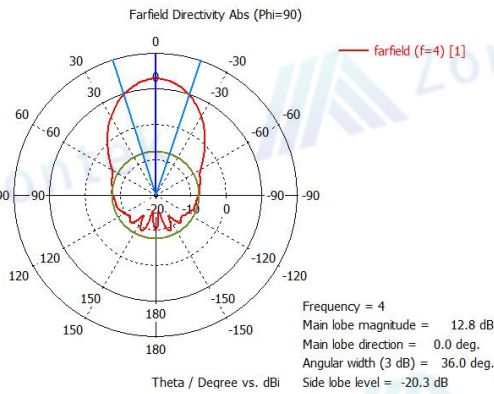

4GHz

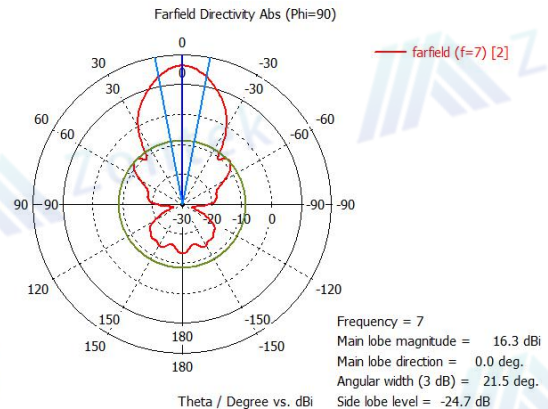
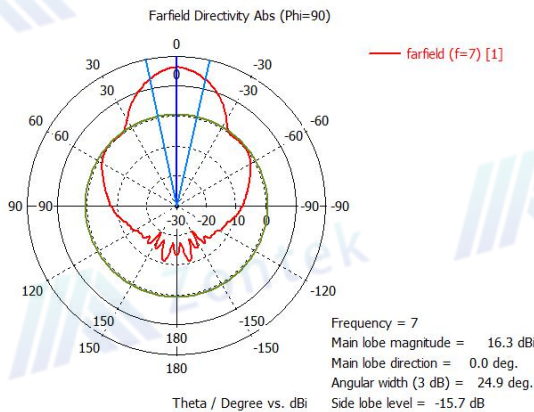

7GHz



Chengdu Zontek Technology Co.,Ltd.

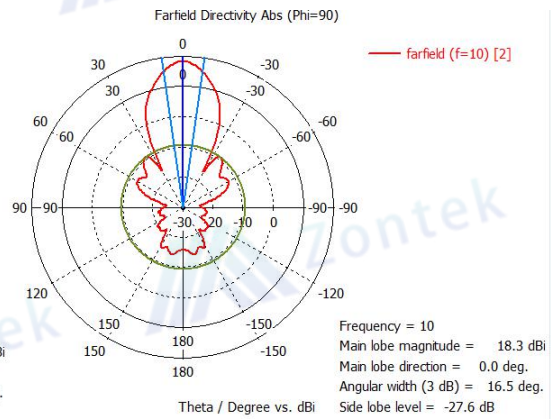
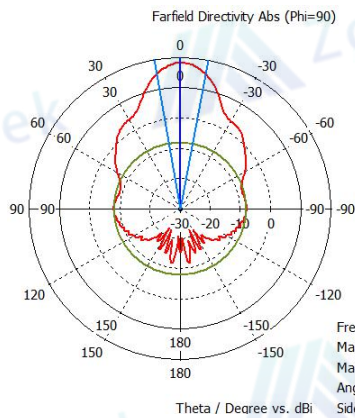

10GHz

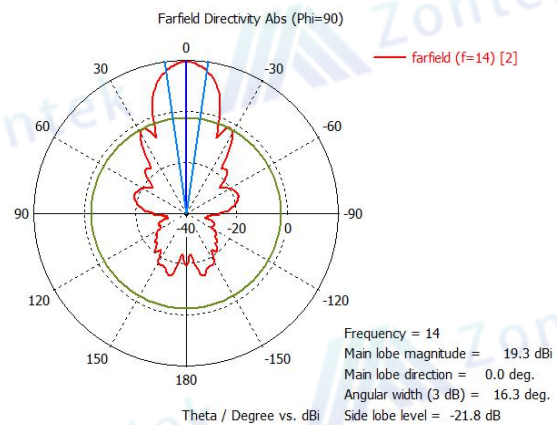
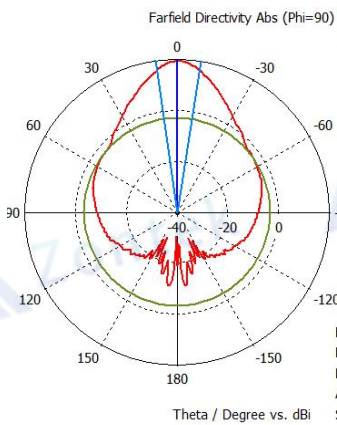

14GHz

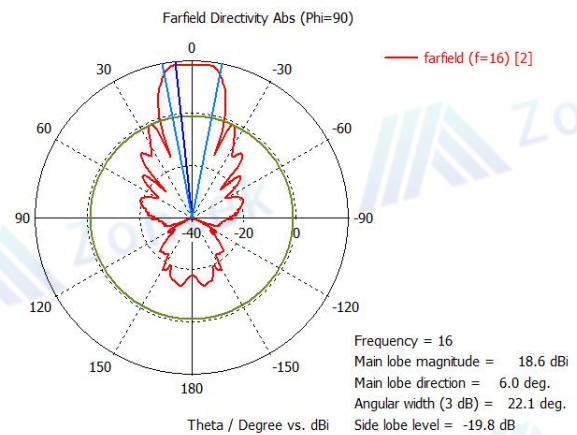
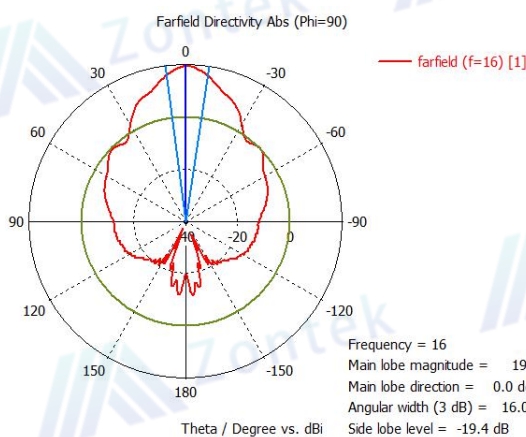

16GHz



Chengdu Zontek Technology Co.,Ltd.

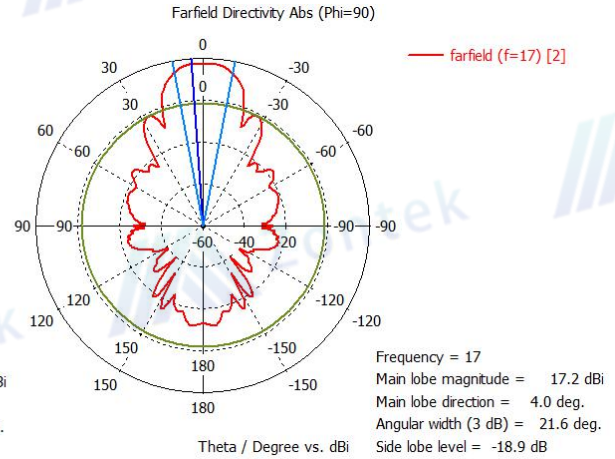
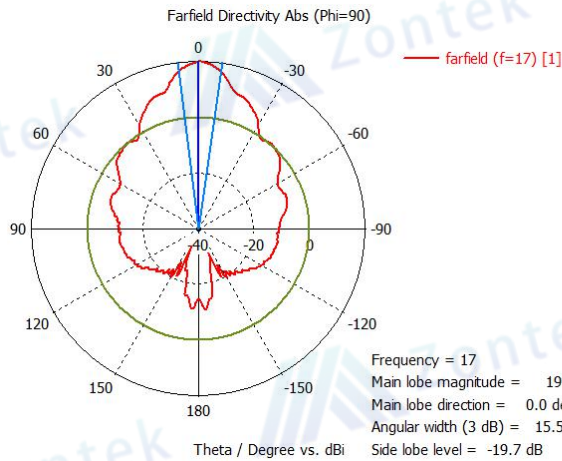

17GHz

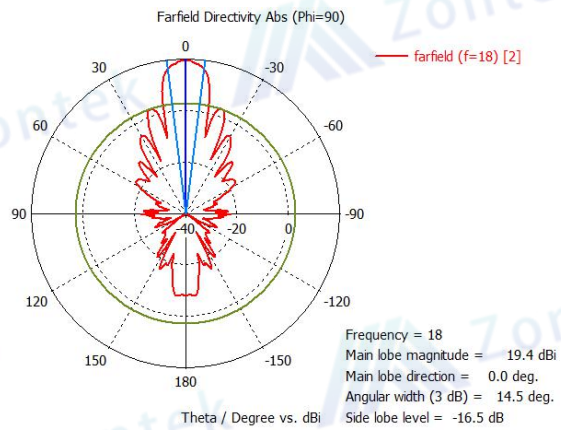
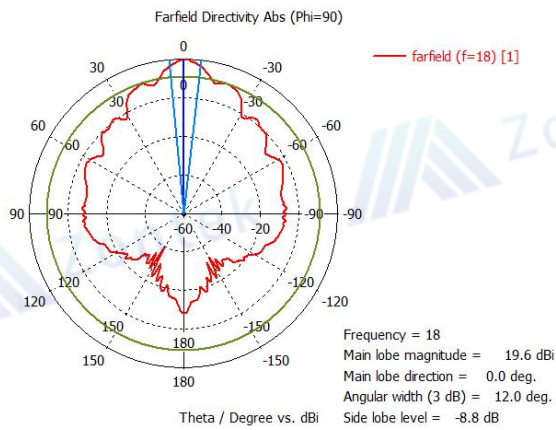

18GHz