

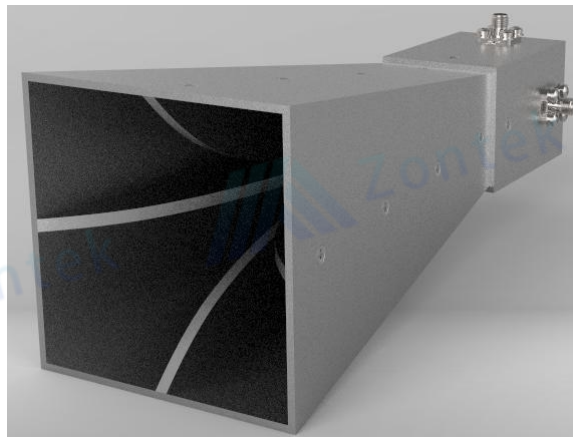

Technical Specification		
Dual Polarization Horn Antenna		
Item	Specification	Unit
Model	ZK-SJLB20180	
Frequency Range	2-18	GHz
Gain	12 Typ.	dB
VSWR	2 Typ.	
Polarization	Dual Linear	
Connector	SMA-50K	
Power Handing(W)	50 Max	
Material	Al	
Color	Grey	
Size	213*79*79	mm





Outline Drawing:

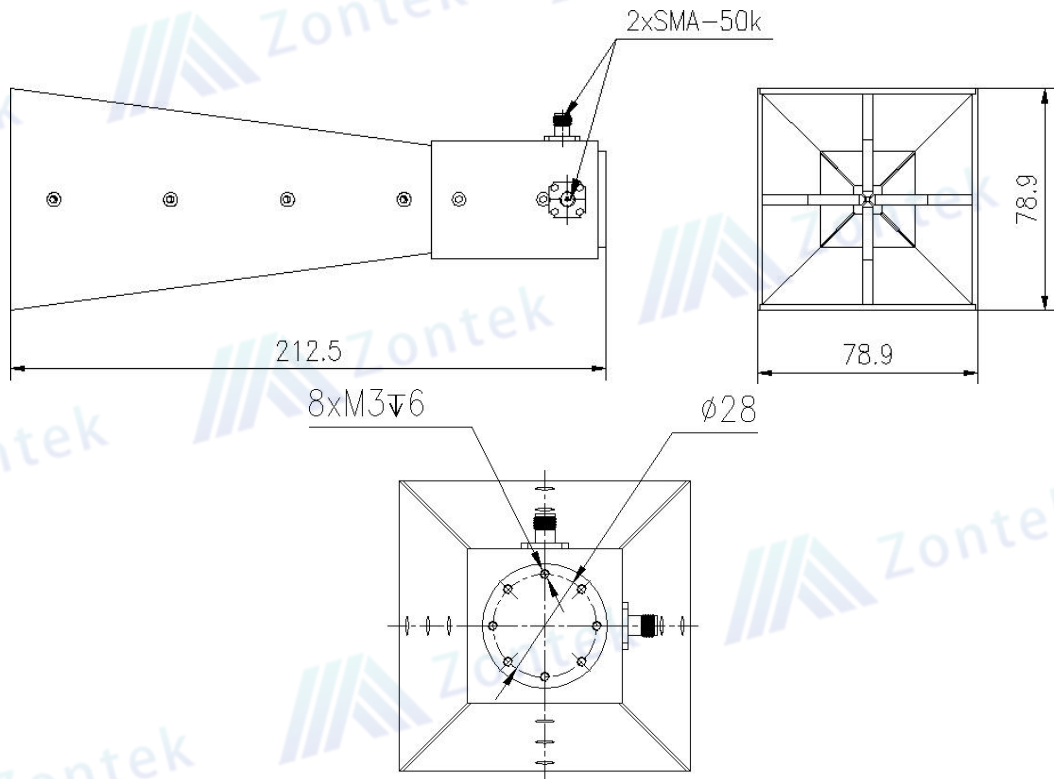

VSWR:

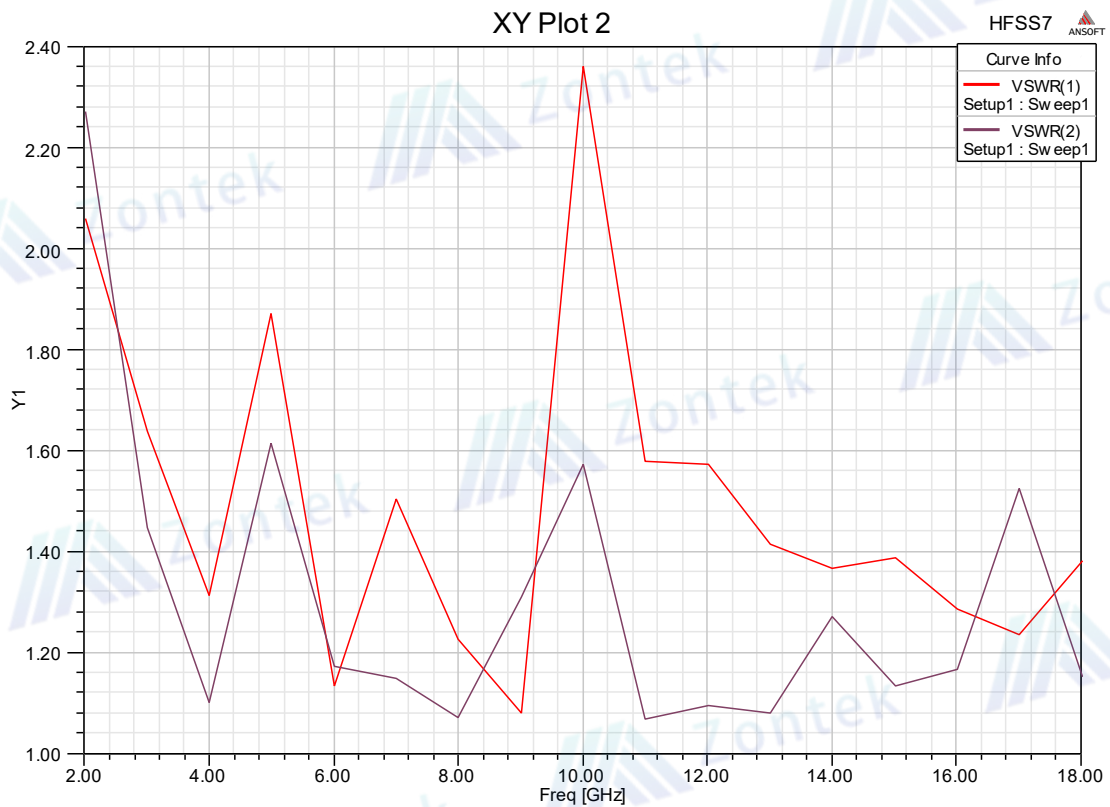



# Chengdu Zontek Technology Co.,Ltd.

Gain:

Name	Theta	Ang	Mag
m1	0.0000	0.0000	5.7628

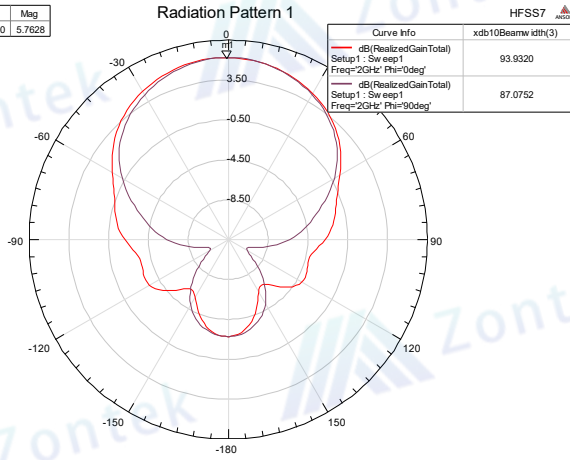

Name	Theta	Ang	Mag
m1	0.0000	0.0000	8.4589

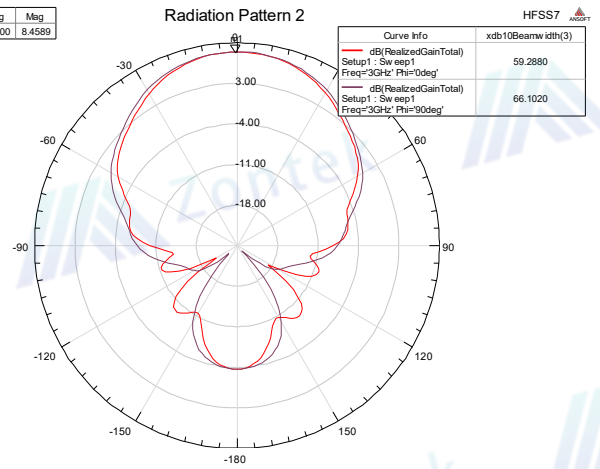

Name	Theta	Ang	Mag
m1	0.0000	0.0000	10.3353

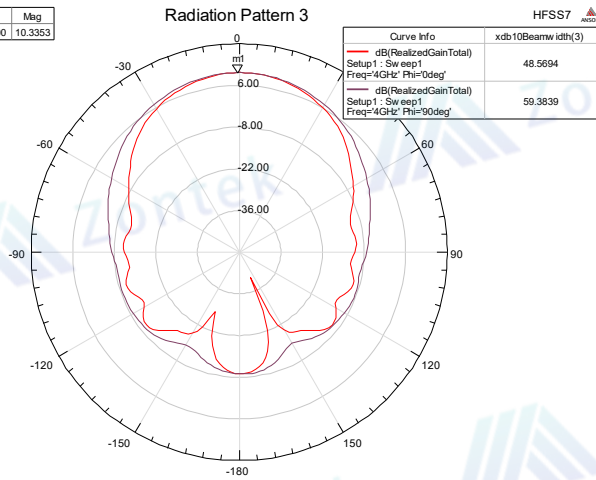

Name	Theta	Ang	Mag
m1	0.0000	0.0000	11.9440

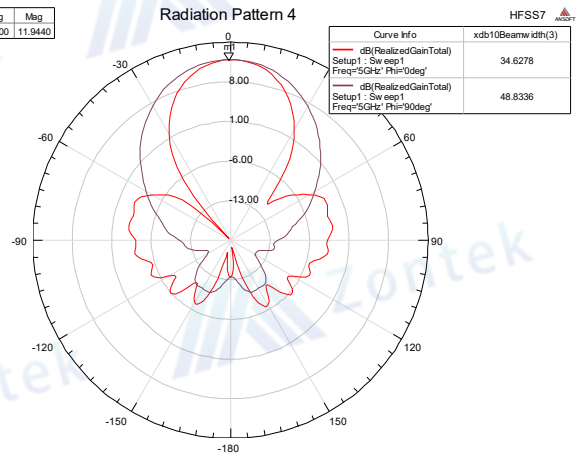

Name	Theta	Ang	Mag
m1	0.0000	0.0000	12.3815

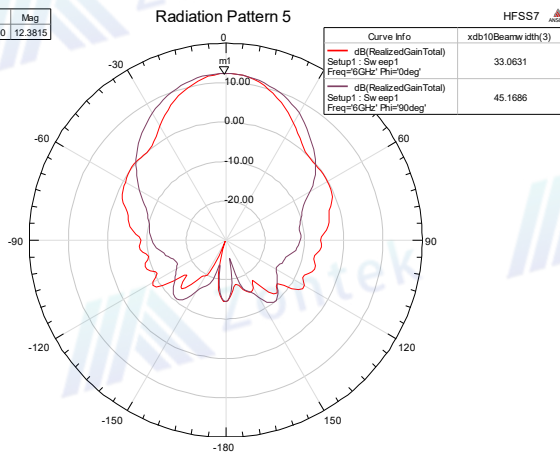

Name	Theta	Ang	Mag
m1	0.0000	0.0000	13.8583

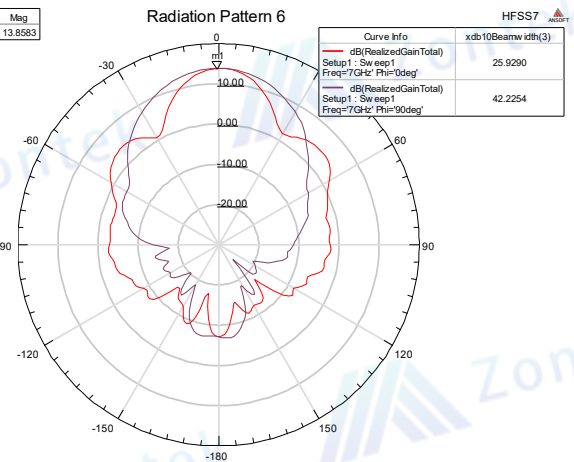



# Chengdu Zontek Technology Co.,Ltd.

Name	Theta	Ang	Mag
mt	0.0000	0.0000	14.6092

### Radiation Pattern 7

HFSS7

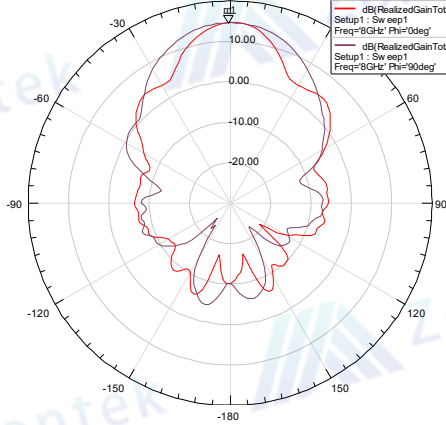

Curve Info		xdB10Beamw idth(3)
dB(RealizedGainTotal)	Setup1 : Sw eep1	25.1973
dB(RealizedGainTotal)	Setup1 : Sw eep1	40.8737

Name	Theta	Ang	Mag
mt	0.0000	0.0000	14.9949

### Radiation Pattern 8

HFSS7

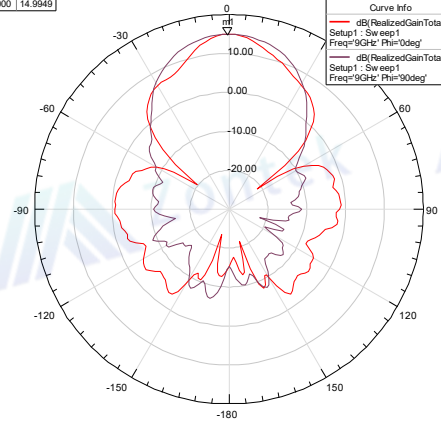

Curve Info		xdB10Beamw idth(3)
dB(RealizedGainTotal)	Setup1 : Sw eep1	24.7035
dB(RealizedGainTotal)	Setup1 : Sw eep1	39.2427

Name	Theta	Ang	Mag
mt	0.0000	0.0000	16.6190

### Radiation Pattern 9

HFSS7

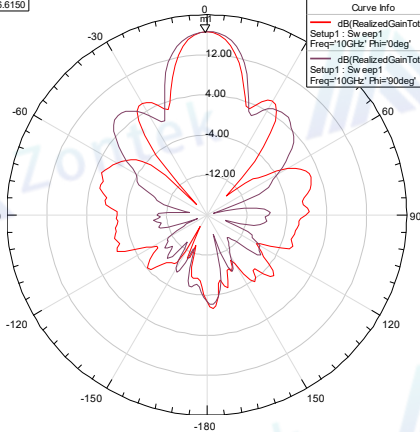

Curve Info		xdB10Beamw idth(3)
dB(RealizedGainTotal)	Setup1 : Sw eep1	17.3033
dB(RealizedGainTotal)	Setup1 : Sw eep1	21.9914

Name	Theta	Ang	Mag
mt	0.0000	0.0000	19.1956

### Radiation Pattern 10

HFSS7

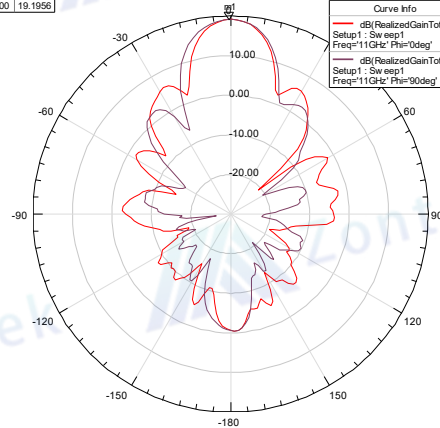

Curve Info		xdB10Beamw idth(3)
dB(RealizedGainTotal)	Setup1 : Sw eep1	18.3734
dB(RealizedGainTotal)	Setup1 : Sw eep1	21.0286

Name	Theta	Ang	Mag
mt	0.0000	0.0000	17.2142

### Radiation Pattern 11

HFSS7

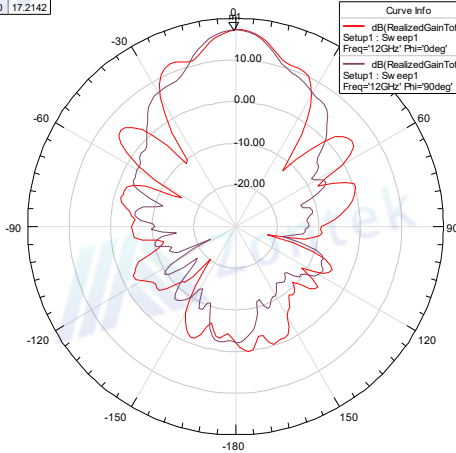

Curve Info		xdB10Beamw idth(3)
dB(RealizedGainTotal)	Setup1 : Sw eep1	19.7378
dB(RealizedGainTotal)	Setup1 : Sw eep1	20.9275

Name	Theta	Ang	Mag
mt	0.0000	0.0000	12.6675

### Radiation Pattern 12

HFSS7

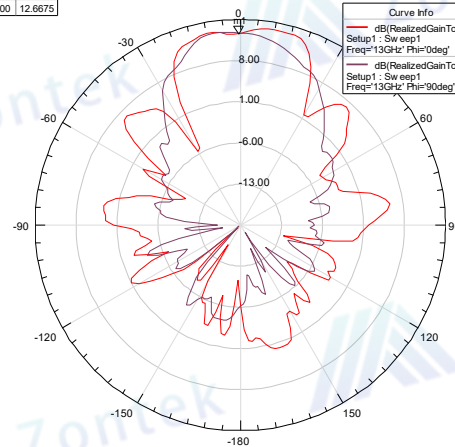

Curve Info		xdB10Beamw idth(3)
dB(RealizedGainTotal)	Setup1 : Sw eep1	43.5391
dB(RealizedGainTotal)	Setup1 : Sw eep1	37.2598



# Chengdu Zontek Technology Co.,Ltd.

Name	Theta	Ang	Mag
m1	0.0000	0.0000	15.3250

### Radiation Pattern 13

HFSS7

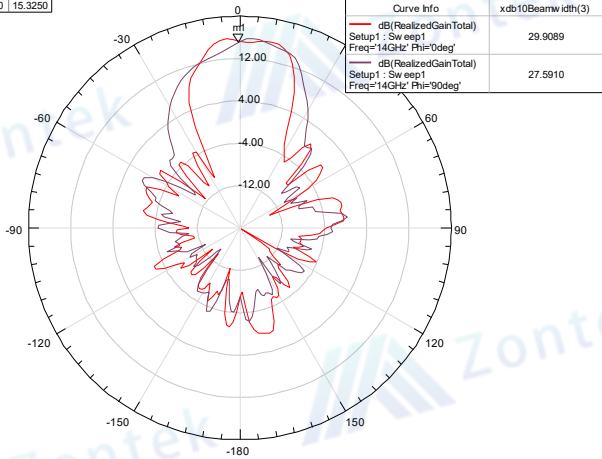

Name	Theta	Ang	Mag
m1	0.0000	0.0000	18.4529

### Radiation Pattern 14

HFSS7

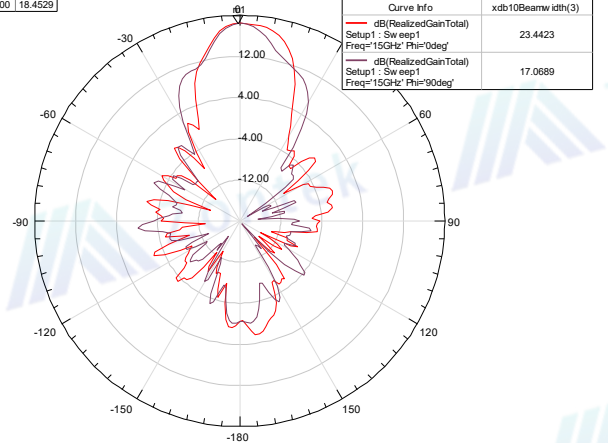

Name	Theta	Ang	Mag
m1	0.0000	0.0000	20.8868

### Radiation Pattern 15

HFSS7

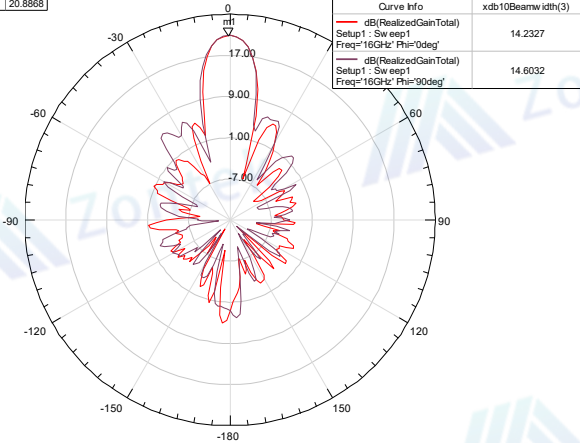

Name	Theta	Ang	Mag
m1	0.0000	0.0000	20.9630

### Radiation Pattern 16

HFSS7

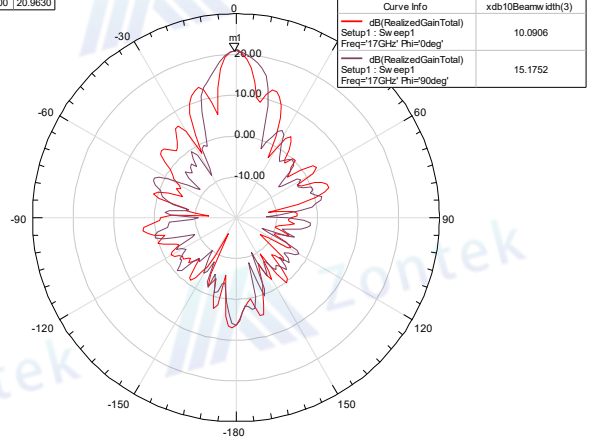

Name	Theta	Ang	Mag
m1	0.0000	0.0000	19.2403

### Radiation Pattern 17

HFSS7

