

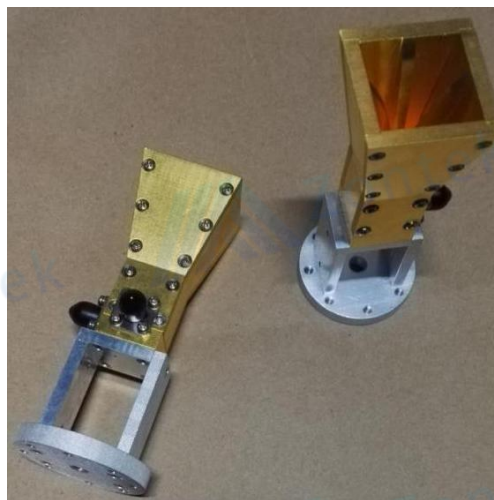

| Technical Specification | | |
|--------------------------------|---------------|------|
| Dual Polarization Horn Antenna | | |
| Item | Specification | Unit |
| Model | ZK-SJLB180400 | |
| Frequency Range | 18-40 | GHz |
| Gain | 15 Typ. | dB |
| VSWR | 2 Typ. | |
| Polarization | Dual Linear | |
| Connector | 2.92mm-50K | |
| Power Handing(W) | 10 Max | |
| Material | Al | |
| Color | Grey | |
| Size | 62*35*35 | mm |





Outline Drawing:

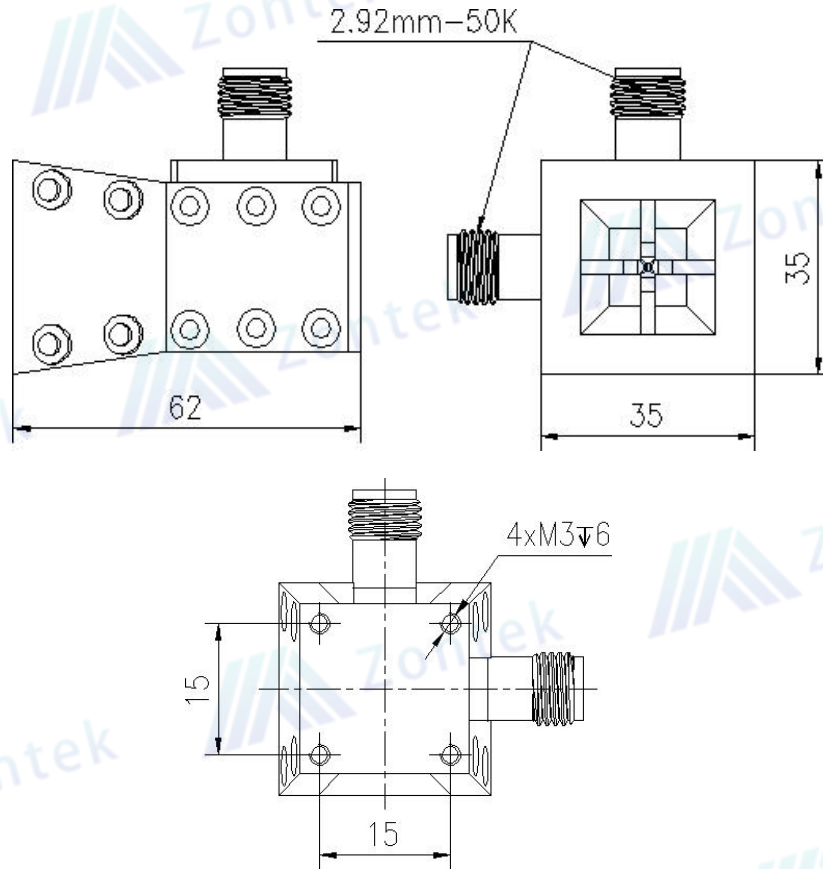

VSWR:

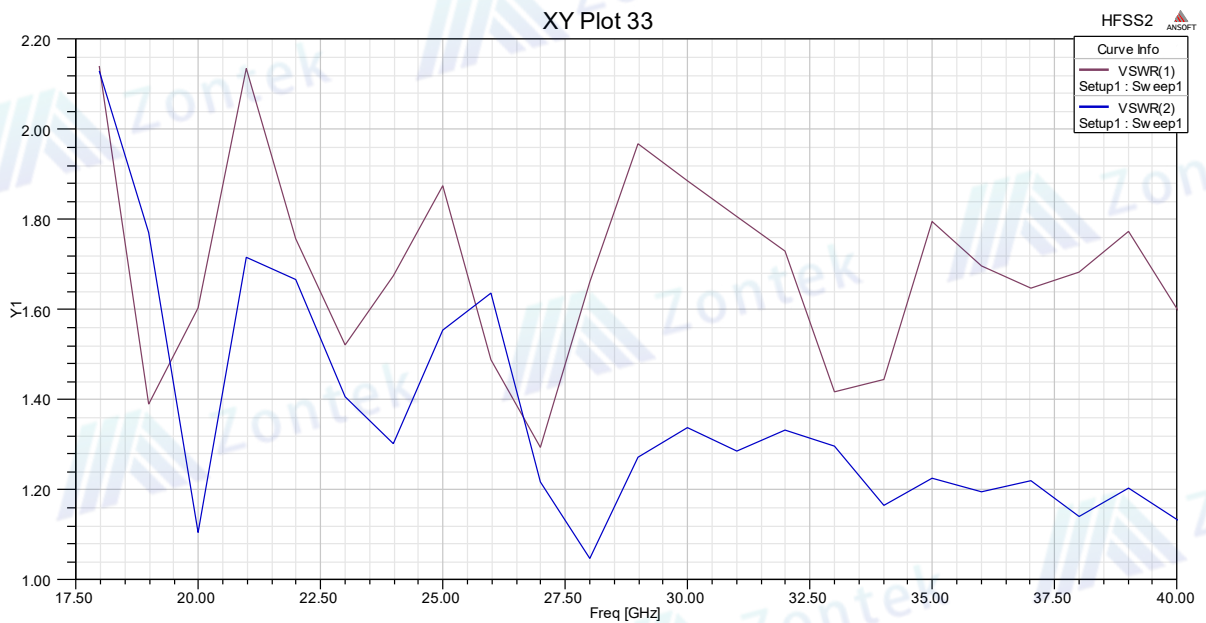



Chengdu Zontek Technology Co.,Ltd.

Gain:

| Name | Theta | Ang | Mag |
|------|--------|--------|---------|
| mt | 0.0000 | 0.0000 | 11.1162 |

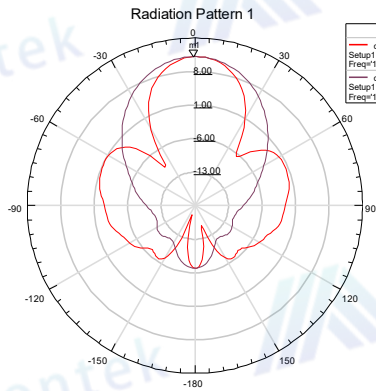

| Name | Theta | Ang | Mag |
|------|--------|--------|---------|
| mt | 0.0000 | 0.0000 | 11.1325 |

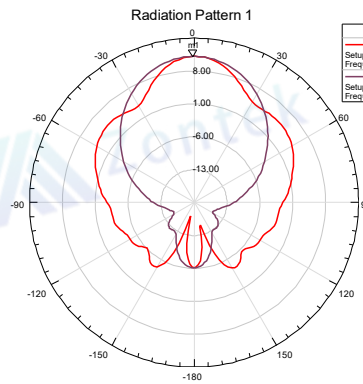

| Curve Info | | xdB10Beamw idth(3) |
|------------------------|------------------|--------------------|
| -dB(RealizedGainTotal) | Setup1 : Sw eep1 | 33.7924 |
| Freq: | 20GHz | Phi=0deg |
| -dB(RealizedGainTotal) | Setup1 : Sw eep1 | 48.6559 |
| Freq: | 20GHz | Phi=90deg |

| Name | Theta | Ang | Mag |
|------|--------|--------|---------|
| mt | 0.0000 | 0.0000 | 11.4527 |

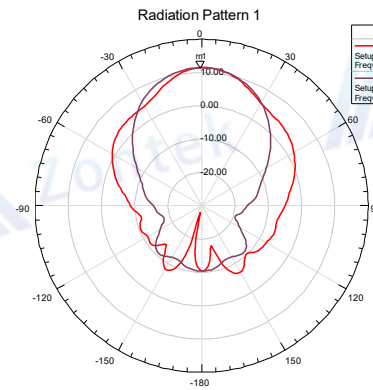

| Name | Theta | Ang | Mag |
|------|--------|--------|---------|
| mt | 0.0000 | 0.0000 | 12.0585 |

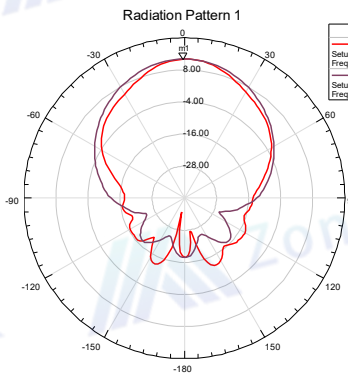

| Curve Info | | xdB10Beamw idth(3) |
|------------------------|------------------|--------------------|
| -dB(RealizedGainTotal) | Setup1 : Sw eep1 | 35.5101 |
| Freq: | 24GHz | Phi=0deg |
| -dB(RealizedGainTotal) | Setup1 : Sw eep1 | 49.6610 |
| Freq: | 24GHz | Phi=90deg |

| Name | Theta | Ang | Mag |
|------|--------|--------|---------|
| mt | 0.0000 | 0.0000 | 12.1505 |

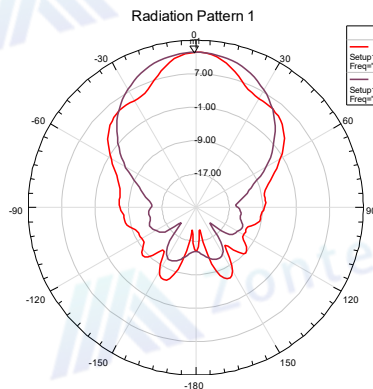

| Name | Theta | Ang | Mag |
|------|--------|--------|---------|
| mt | 0.0000 | 0.0000 | 13.9051 |

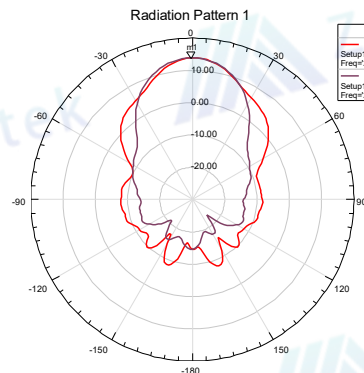

| Curve Info | | xdB10Beamw idth(3) |
|------------------------|------------------|--------------------|
| -dB(RealizedGainTotal) | Setup1 : Sw eep1 | 29.2759 |
| Freq: | 28GHz | Phi=0deg |
| -dB(RealizedGainTotal) | Setup1 : Sw eep1 | 33.2873 |
| Freq: | 28GHz | Phi=90deg |



Chengdu Zontek Technology Co.,Ltd.

| Name | Theta | Ang | Mag |
|------|--------|--------|---------|
| m1 | 0.0000 | 0.0000 | 13.7304 |

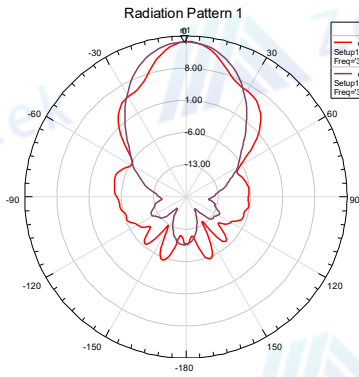

| Curve Info | | HFSS2 |
|-----------------|-----------------------|--------------------|
| — | dB(RealizedGainTotal) | xdb10Beamw idth(3) |
| Setup1 : SwEEP1 | Freq=30GHz; Phi=0deg | 25.5785 |
| Setup1 : SwEEP1 | Freq=30GHz; Phi=90deg | 35.7672 |

| Name | Theta | Ang | Mag |
|------|--------|--------|---------|
| m1 | 0.0000 | 0.0000 | 13.8534 |

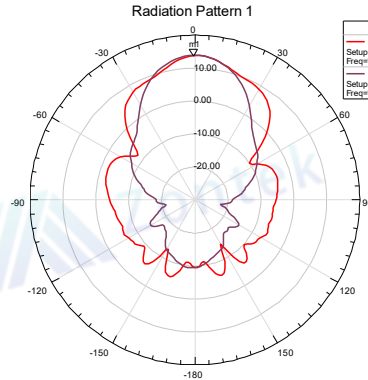

| Curve Info | | HFSS2 |
|-----------------|-----------------------|--------------------|
| — | dB(RealizedGainTotal) | xdb10Beamw idth(3) |
| Setup1 : SwEEP1 | Freq=32GHz; Phi=0deg | 29.0519 |
| Setup1 : SwEEP1 | Freq=32GHz; Phi=90deg | 31.1832 |

| Name | Theta | Ang | Mag |
|------|--------|--------|---------|
| m1 | 0.0000 | 0.0000 | 14.2388 |

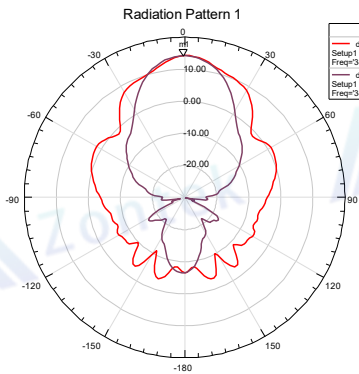

| Curve Info | | HFSS2 |
|-----------------|-----------------------|--------------------|
| — | dB(RealizedGainTotal) | xdb10Beamw idth(3) |
| Setup1 : SwEEP1 | Freq=34GHz; Phi=0deg | 28.2177 |
| Setup1 : SwEEP1 | Freq=34GHz; Phi=90deg | 27.9308 |

| Name | Theta | Ang | Mag |
|------|--------|--------|---------|
| m1 | 0.0000 | 0.0000 | 13.0988 |

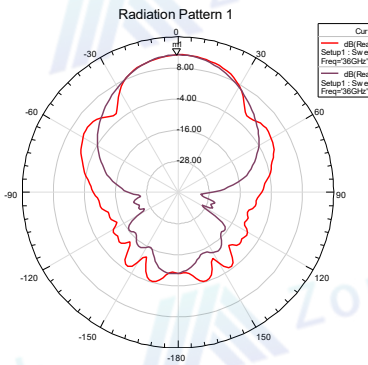

| Curve Info | | HFSS2 |
|-----------------|-----------------------|--------------------|
| — | dB(RealizedGainTotal) | xdb10Beamw idth(3) |
| Setup1 : SwEEP1 | Freq=36GHz; Phi=0deg | 43.1867 |
| Setup1 : SwEEP1 | Freq=36GHz; Phi=90deg | 39.0683 |

| Name | Theta | Ang | Mag |
|------|--------|--------|---------|
| m1 | 0.0000 | 0.0000 | 15.0549 |

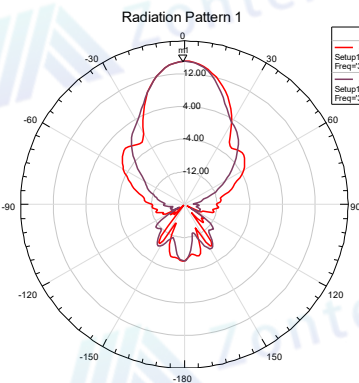

| Curve Info | | HFSS2 |
|-----------------|-----------------------|--------------------|
| — | dB(RealizedGainTotal) | xdb10Beamw idth(3) |
| Setup1 : SwEEP1 | Freq=38GHz; Phi=0deg | 26.5551 |
| Setup1 : SwEEP1 | Freq=38GHz; Phi=90deg | 24.6757 |

| Name | Theta | Ang | Mag |
|------|--------|--------|---------|
| m1 | 0.0000 | 0.0000 | 16.8793 |

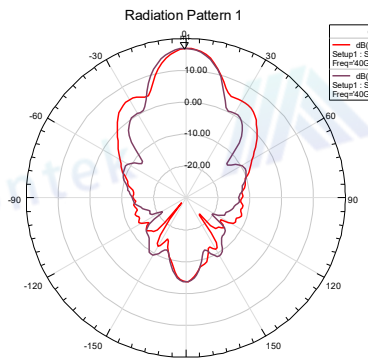

| Curve Info | | HFSS2 |
|-----------------|-----------------------|--------------------|
| — | dB(RealizedGainTotal) | xdb10Beamw idth(3) |
| Setup1 : SwEEP1 | Freq=40GHz; Phi=0deg | 19.5726 |
| Setup1 : SwEEP1 | Freq=40GHz; Phi=90deg | 20.9835 |