

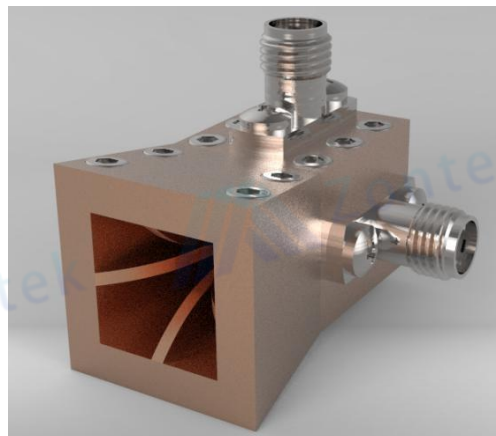

Technical Specification		
Dual Polarization Horn Antenna		
Item	Specification	Unit
Model	ZK-SJLB240500	
Frequency Range	24-50	GHz
Gain	10 Typ.	dB
VSWR	2 Typ.	
Polarization	Dual Linear	
Connector	1.85mm	
Power Handing(W)	10 Max	
Material	Al	
Color	Grey	
Size	31*17*17	mm





Outline Drawing:

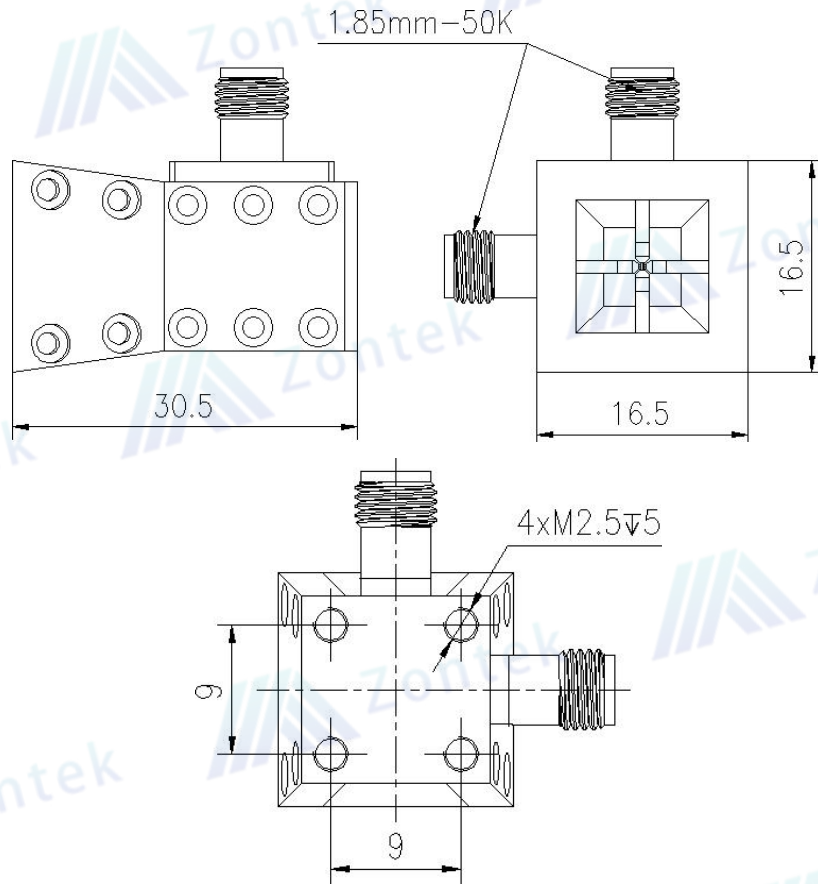

VSWR:

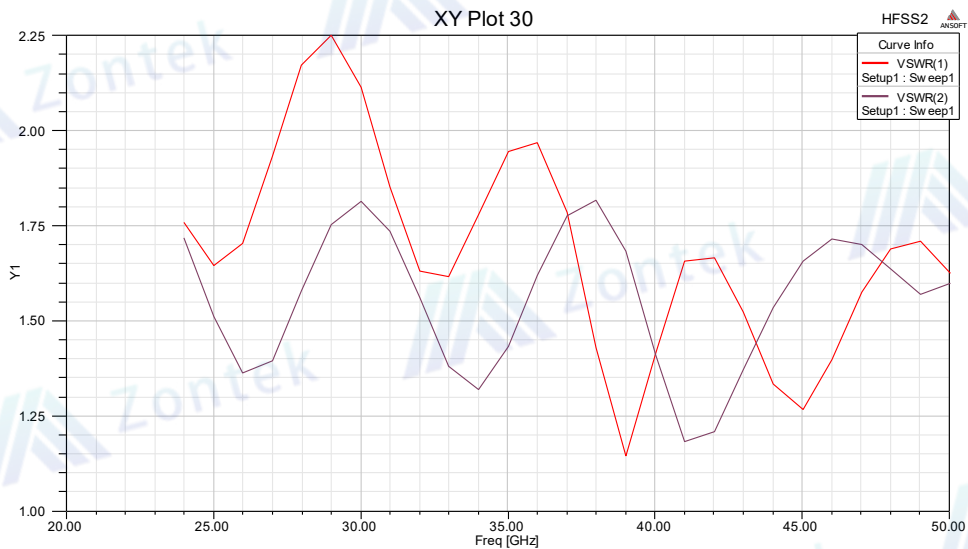



Chengdu Zontek Technology Co.,Ltd.

Gain:

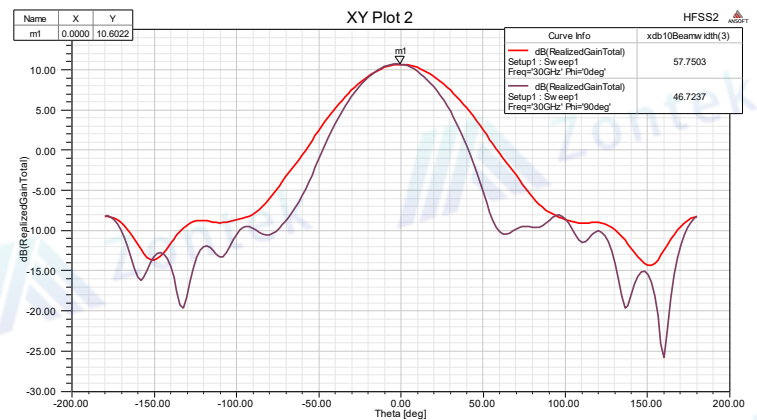
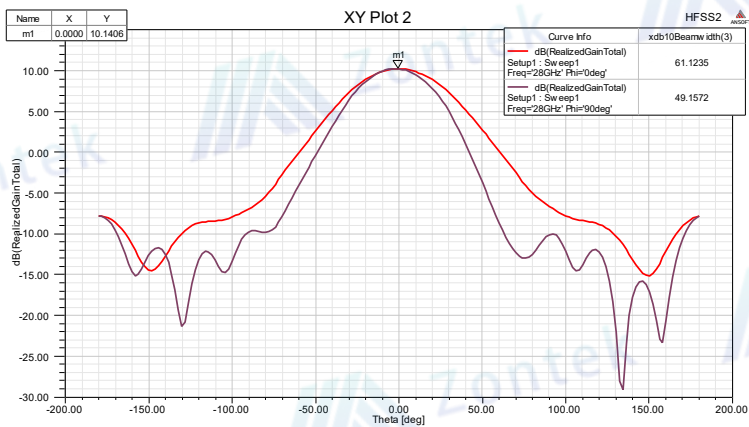
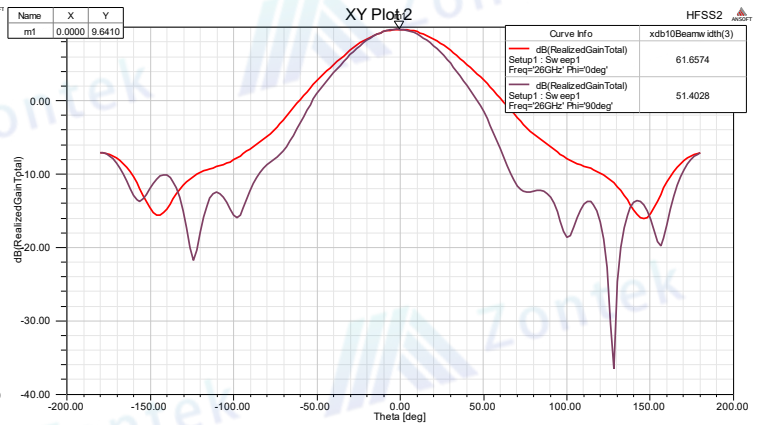
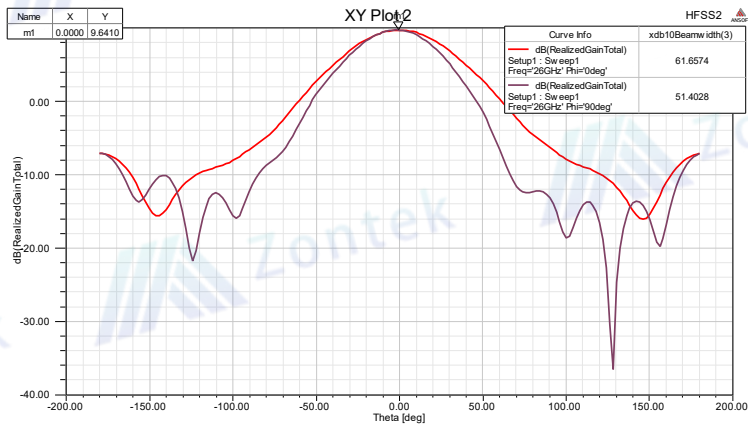
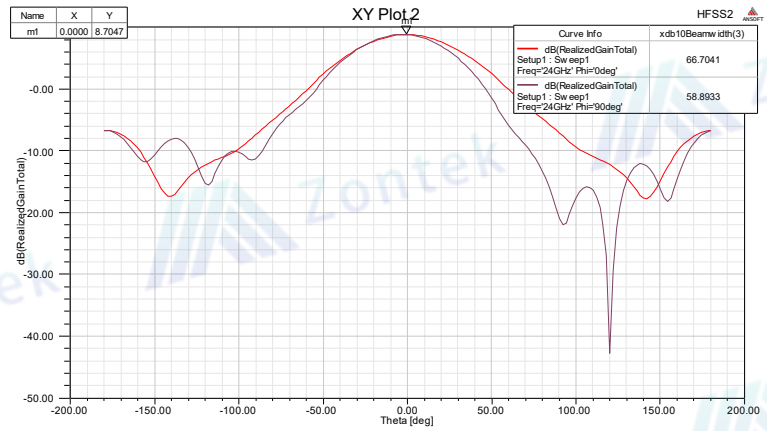
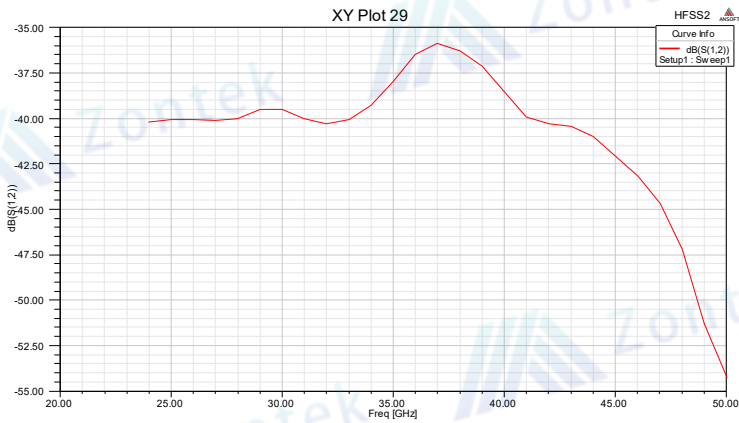



Chengdu Zontek Technology Co.,Ltd.

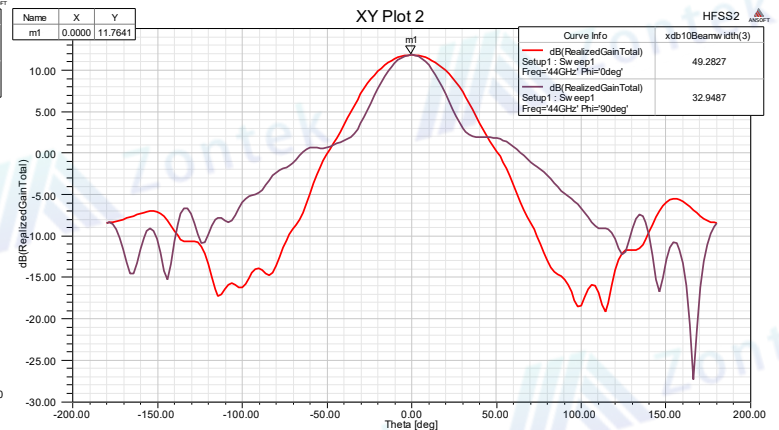
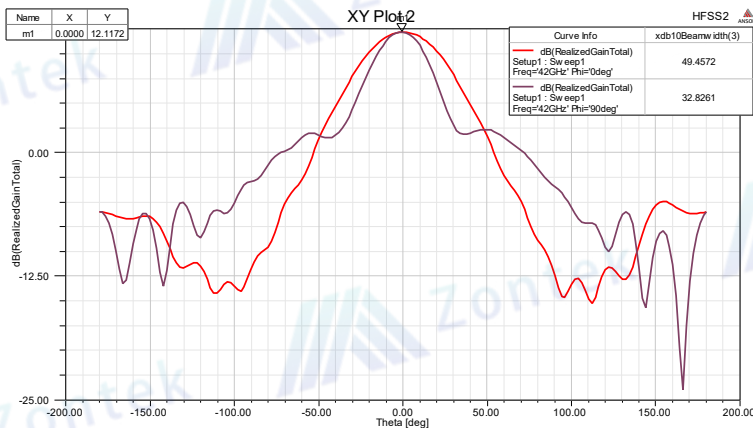
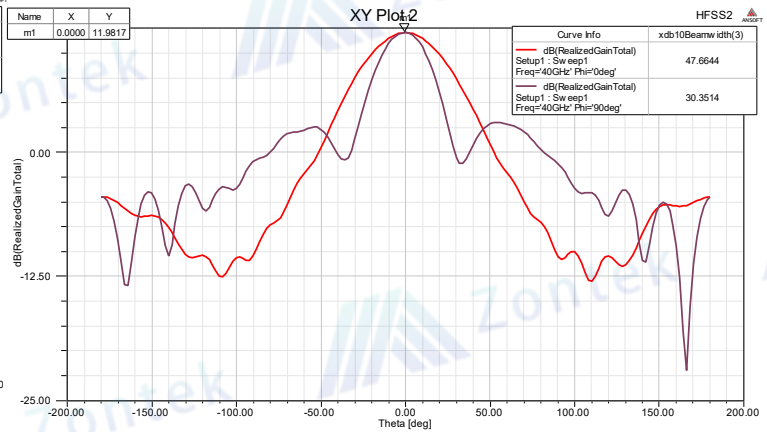
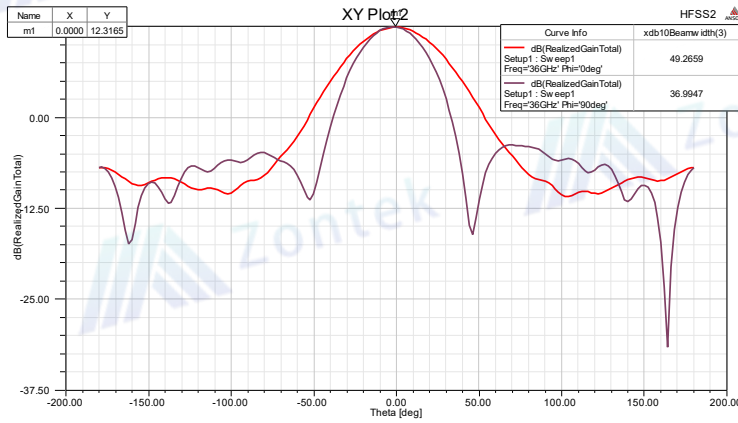
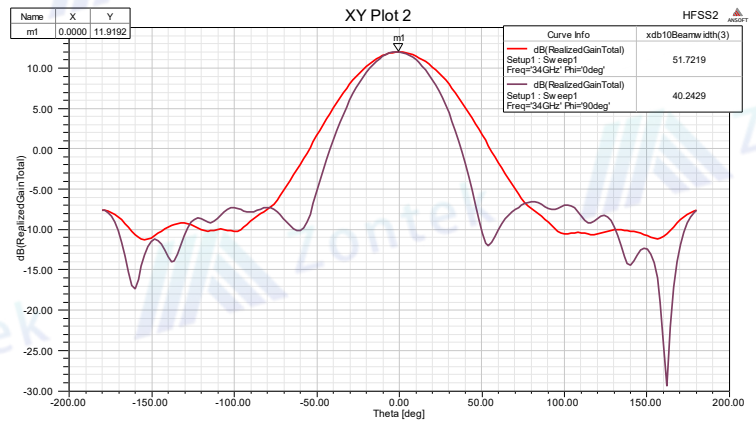
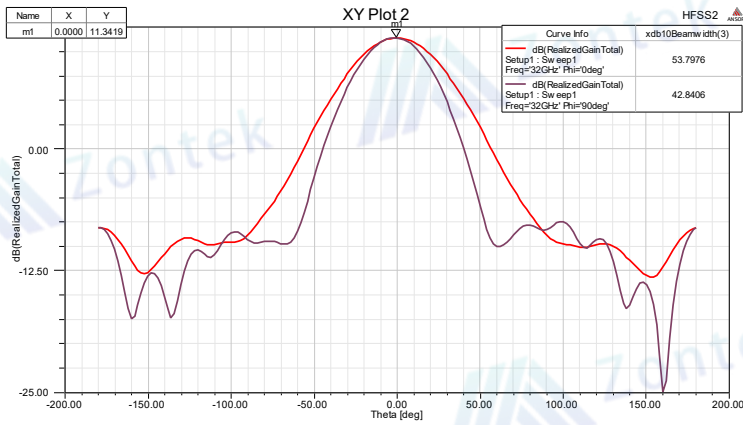



Chengdu Zontek Technology Co.,Ltd.

